

FOURTH CLASS MARINE ENGINEER EXAMINATION

CANDIDATES' GUIDE TO MULTIPLE CHOICE
TYPE EXAMINATIONS

CONTENTS

General Information	Page	1
Examination Rules to be Observed by Candidates	"	1
Completion of the Answer Sheet	"	3
Syllabus	"	5
Practice Questions with Answers	"	14

Marine Engineer Examinations
Ship Safety Branch
Canadian Coast Guard
Ottawa, Ontario.

September 1976

①

①

W. Bantle

GENERAL INFORMATION

1. The purpose of this guide is to provide a candidate for a fourth class certificate with information and the procedures of the fourth class multiple choice type examination.

2. Every candidate for a fourth class certificate shall undergo written multiple choice type examinations in two subjects for either a steam certificate or a motor certificate, and in three subjects for a combined certificate, as follows:

- a) E.K. Steam and E.K. General; or
- b) E.K. Motor and E.K. General; or
- c) E.K. Steam, E.K. Motor, and E.K. General.

3. A copy of the syllabus for the examination commences on page 5 of this guide. Each candidate should be prepared to answer questions on any of the areas of knowledge referred to in the syllabus, in the appropriate subjects in which the candidate will be examined.

4. On completion of the written examination each candidate shall undergo an oral examination to test his practical knowledge of the appropriate subjects and the oral examination may include references to the candidate's answers in the written examination.

5. For each subject of the written examination each candidate will be given three examination question books which together contain the total number of questions for that subject. Before commencing the examination the candidate should ensure that the question books are in numerical order, and if in doubt obtain the advice of the Examiner.

6. Below each question is listed four alternative answers, read each question carefully, study the alternatives, and select the answer which you consider is correct. On pages 14 to 20 of this guide are some practice questions, attempt to answer these questions and check your answers with the correct answers marked on the specimen answer sheet on page 21.

EXAMINATION RULES TO BE OBSERVED BY CANDIDATES

7. Any books, notes, memorandums, etc., which a candidate may have brought to the examination must be handed to the Examiner on entering the examination room.

8. A candidate using books or information other than that supplied by the Examiner will be penalized by failure.

9. A candidate who receives information from, or imparts information to another candidate, or communicates with another candidate in any way while the examination is in progress may be penalized by failure.

②

②

10. A candidate must not leave the examination room unless permitted to do so by the Examiner.
11. Silence is to be observed during the examination.
12. A candidate must return all question books and answer sheets to the Examiner at the end of the examination.
13. The question books must not be marked or defaced in any way.
14. A candidate who has been failed through not observing the rules in Section 8 or 9 will not be allowed to sit for examination again for a period of from three to six months as may be decided by the Board of Steamship Inspection.

COMPLETION OF THE ANSWER SHEET

15. On page 2 you will see a specimen answer sheet completed by a candidate for the Engineering Knowledge, Motor examination.
16. Use the soft black lead pencil provided for marking the answer sheet.
17. On the left hand side of the ~~sheet~~ enter the following information:
 - a) print your name in the space provided;
 - b) print the name of the examination subject (i.e. General, Steam or Motor) in the space marked COMP. NO; and
 - c) enter the date on which the examination is written in the space provided.Turn the answer sheet over to the blank side and write your signature at the bottom of the page.
18. The numbers corresponding to the questions in the books are located in the shaded columns and read from left to right, commencing from the top left corner. Alongside each number are five blank rectangles. As there are only four alternative answers to each question your answer must be marked in either rectangle number 1, 2, 3 or 4.
19. For each question you must record your answer by making a heavy black pencil mark in the rectangle with the same number as the alternative answer which you consider to be correct. Be sure that each mark completely fills the rectangle.

③

③

20. If you wish to change an answer, or you have put a mark in the wrong rectangle, be sure to completely erase the mark. You will not be credited with a correct answer for any question number alongside which appears more than one mark.

21. Do not put any other unnecessary marks on the answer sheet.

SYLLABUS

In the examination for a fourth class marine engineer certificate of competency the knowledge to be shown by a candidate is that required by a watchkeeping engineer, including that of the safe and efficient operation, surveillance and running maintenance of ships' machinery.

For a period of twelve months after the introduction (coming into force) of the multiple choice type examination, no examination given to a candidate will include questions on the following areas of knowledge:

- a) mathematics;
- b) mechanics;
- c) lifesaving;
- d) basic first aid; and
- e) pollution prevention.

In both the written and oral examinations certain questions, especially those which require a knowledge of the dangers, causes and control of fires and explosions in steam and motor ships, are regarded as being very important. Lack of knowledge in these areas and failure to correctly answer these questions can lead to failure in the examination. By way of example, questions on the following areas of knowledge are included in the examination and must be answered correctly to pass:

- a) water gauge readings and testing for accuracy;
- b) the precautions to be taken
 - (i) when blowing-down a boiler,
 - (ii) to prevent the contents of a boiler backing into another boiler through blow-down or scum valves,
 - (iii) when re-lighting an oil fired furnace in which unburnt gases or oil fuel may have accumulated,
 - (iv) when connecting one boiler to another, with regard to the effects of water hammer,
 - (v) when bunkering and transferring oil fuels, and
 - (vi) to prevent fires and explosions in compressed air lines and air compressors;
- c) the precautions to be taken and the safeguards necessary to prevent crankcase explosions; and
- d) the precautions to be taken and the hazards involved with regard to the temperature of diesel engine exhaust manifolds and piping.

Engineer Knowledge, General

1. (1) Construction and safe use of hand tools:
 - a) hammers, screw-drivers, wrenches, drift punches;
 - b) chisels, hand saws and blades, files, hand shears and snips;
 - c) twist drills, reamers, taps and dies; and
 - d) portable power tools.

- (2) Materials of construction:
 - a) the use of materials and the ability to distinguish between the following common types: steels, cast-irons, copper, zinc, brass and aluminum.

- (3) Physical Science:
 - a) mathematics:
 - (i) fundamental arithmetical operations and percentages, and
 - (ii) the measurement of length, mass, area, volume, and of pressure and temperature, in S.I. units;

 - b) mechanics:
 - (i) force, friction, energy, power, and
 - (ii) the following simple machines: the lever and the wheel and axle; and

 - c) instruments and equipment for measuring and testing:
 - (i) the principles, construction and operation of the more usual instruments employed for the control and operation of ships' machinery,
 - (ii) the measurement of temperature, pressure, mass and length,
 - (iii) the measurement of voltage, current and resistance,
 - (iv) the testing of oil and water, and
 - (v) the testing of combustion products.

- (4) Fire prevention, detection and extinguishing:
 - a) the chemistry of fire;
 - b) recognition of fire hazards; and

- c) identification, maintenance and use of the following:
- (i) portable fire extinguishers,
 - (ii) fire hydrants, hoses and nozzles,
 - (iii) fire doors and water-tight doors,
 - (iv) detection devices, alarms and alarm systems,
 - (v) fire pumps,
 - (vi) breathing apparatus, and
 - (vii) sprinkler and smothering systems.
- (5) Life saving:
- a) the use of lifejackets, lifeboats, inflatable life rafts, and distress signals; and
 - b) a knowledge of emergency duties, stations and drills.
- (6) Basic first aid:
- a) treatment for sudden illness and accidents, including cuts, burns, fractures and asphyxia.
- (7) Safe working practices:
- a) work procedures and precautions necessary to prevent hazards and to maintain safe working conditions.
- (8) Pollution prevention:
- a) a basic knowledge of the pollution prevention laws and regulations applicable to ships; and
 - b) a knowledge of pollution prevention procedures, including bunkering operations, the discharge of bilge and ballast water, and the operation of oily-water separators.
- (9) Pumps and piping:
- a) construction, operation and maintenance of the following:
 - (i) reciprocating pumps,
 - (ii) centrifugal pumps,
 - (iii) screw-displacement and gear pumps, and
 - (iv) injectors and ejectors; and

- b) piping:
- (i) steam and feed water systems,
 - (ii) bilge and ballast systems,
 - (iii) fuel and lubricating oil systems,
 - (iv) valves, drains, traps and other fittings, and
 - (v) the precautions to be observed in the operation of piping systems with regard to pipe expansion, water hammer, cross connections, venting and overflow.
- (10) Power transmission:
- a) thrust, intermediate and propeller shafts;
 - b) thrust, intermediate and propeller shaft bearings;
 - c) alignment;
 - d) couplings; and
 - e) gear types and systems.
- (11) Steering gear:
- a) common types of steering gear; and
 - b) emergency steering gear.
- (12) Underwater fittings:
- a) rudders;
 - b) propellers;
 - c) stern glands; and
 - d) sea suction and discharge valves, and mountings on the hull.
- (13) Deck-machinery:
- a) windlass, capstan and winch.
- (14) Fuels:
- a) types of fuel; and
 - b) the storage, transfer, heating, filtration and purification of fuels.
- (15) Lubricants:
- a) types of lubricants and their application; and
 - b) the storage, transfer, heating, cooling, filtration, purification and disposal of lubricants.

- (16) Electricity and magnetism:
- a) fundamentals:
 - (i) direct and alternating current,
 - (ii) definitions of current, pressure, resistance, and power,
 - (iii) conductors and insulators,
 - (iv) wet and dry cells, and
 - (v) the identification of simple circuits;
 - b) measurement and protective devices:
 - (i) voltmeter, ammeter, and ohmmeter, and
 - (ii) ground lights, fuses and circuit breakers;
 - c) generators, alternators and motors:
 - (i) construction and operation of d.c. machines,
 - (ii) construction and operation of a.c. machines, and
 - (iii) a knowledge of basic maintenance procedures; and
 - d) electric circuits:
 - (i) alarm circuits,
 - (ii) navigation light circuits,
 - (iii) main and emergency light and power circuits, and
 - (iv) a knowledge of basic maintenance procedures.
- (17) Hydraulic systems:
- a) pumps, motors, piping, fittings and control devices;
 - b) hydraulic fluids; and
 - c) packings and seals.
- (18) Pneumatic systems:
- a) compressors, air receivers, heat exchangers, filters, piping, fittings and control devices; and
 - b) precautions and safe guards necessary to prevent fires and explosions.
- (19) Refrigeration:
- a) construction and operation of refrigeration systems; and
 - b) types, properties and hazards of refrigerants.

- (20) Auxiliary boilers and equipment:
- a) types and construction of boilers;
 - b) operating and safety procedures;
 - c) mountings and fittings;
 - d) fuel system;
 - e) feed system; and
 - f) heat exchangers.
- (21) Auxiliary internal combustion engines:
- a) basic construction and operating procedures;
 - b) cooling and lubrication systems;
 - c) fuel systems, including fuel pumps and injectors;
 - d) starting devices;
 - e) recognition and correction of malfunctions; and
 - f) precautions and safe guards necessary to prevent crankcase explosions.

Engineering Knowledge, Motor

2. (1) Compression ignition engines:
- a) general principles of construction and operation of two stroke and four stroke cycle engines;
 - b) methods of supercharging, turbocharging and scavenging;
 - c) methods of starting and reversing;
 - d) power transmission systems, including couplings, clutches and gears; and
 - e) the following applications of the compression ignition engine in:
 - (i) a single engine installation,
 - (ii) a multiple engine installation, and
 - (iii) a diesel electric installation.
- (2) Lubrication systems:
- a) lubricants and lubricant additives;
 - b) pumps, piping, heat exchangers and filters; and
 - c) the construction, operation and maintenance of purifiers.
- (3) Cooling systems:
- a) air and liquid cooling;
 - b) pumps, piping and heat exchangers; and
 - c) temperature control and expansion arrangements.

- (4) Fuel:
 - a) fuels and fuel additives;
 - b) heating, filtration and purification;
 - c) piping; and
 - d) injection pumps and injectors.
- (5) Governors:
 - a) general principles of construction, operation and maintenance of mechanical, hydraulic and pneumatic governors.
- (6) Maintenance:
 - a) overhaul, repair, adjustment and lay-up of engines, transmissions and inter-related systems, including lubrication, cooling, fuel, compressed air and exhaust systems; and
 - b) preventive maintenance, including running repairs and recognition and correction of malfunctions.

Engineering Knowledge, Steam

- 3. (1) Boilers:
 - a) types:
 - (i) fire tube and water tube boilers;
 - b) construction:
 - (i) parts of the boiler,
 - (ii) method of joining parts by rivetting, welding, threading and bolting, staying and expanding, and
 - (iii) insulation and brickwork;
 - c) mountings:
 - (i) safety valves, water-gauges, main and auxiliary steam and feed water valves, blow-down valves, connections for valves, and fittings for gauges and regulating devices;
 - d) air preheaters:
 - (i) types, and
 - (ii) construction, operation and maintenance;
 - e) economisers:
 - (i) types, and
 - (ii) construction, operation and maintenance;

- f) superheaters:
 - (i) types, and
 - (ii) construction, operation and maintenance; and
 - g) operation and maintenance:
 - (i) raising steam, steaming, blowing-down and shut-down,
 - (ii) water gauge readings and testing for accuracy,
 - (iii) high/low water levels, priming and foaming,
 - (iv) combustion of fuels, oil fuel burners and controls, precautions to be observed,
 - (v) basic knowledge of boiler and feed water treatment, and
 - (vi) opening-up, cleaning and preparation for inspection and lay-up.
- (2) Steam plant ancillary equipment:
- a) construction, operation and maintenance of:
 - (i) oil fuel pumps,
 - (ii) feed water pumps and injectors,
 - (iii) combustion air fans and blowers,
 - (iv) steam separators,
 - (v) steam traps,
 - (vi) feed water heaters and filters,
 - (vii) cooling and circulating water pumps,
 - (viii) condensers, air pumps and air ejectors, and
 - (ix) evaporators and distillers.
- (3) Reciprocating engines:
- a) general principles of construction, operation and maintenance of the different types of engines;
 - b) lubrication systems; and
 - c) the construction, operation and maintenance of governors.
- (4) Turbines:
- a) general principles of construction, operation and maintenance of the different types of turbines;
 - b) power transmission systems, including couplings, gears and turbo-electric installations;

- c) lubrication systems:
 - (i) pumps, piping, heat exchangers and filters, and
 - (ii) the construction, operation and maintenance of purifiers; and
- d) the construction, operation and maintenance of governors.

PRACTICE QUESTIONS WITH ANSWERS

1.

40 02 01 02 07

A RECTANGULAR PLATE MEASURES 500 mm BY 250 mm. THE AREA IS _____ m².

- (1) 12.5
- (2) 125
- (3) 0.125
- (4) 0.00125

2.

40 02 02 01 01

THE WORK DONE IN MOVING AN OBJECT THROUGH A CERTAIN DISTANCE IS ACCOMPLISHED BY THE APPLICATION OF A:

- (1) torque,
- (2) moment,
- (3) couple,
- (4) force. -

3.

40 03 01 02 14

THE RISK OF FIRE IN THE ENGINE ROOM MAY BE REDUCED BY:

- (1) washing bilges with water,
- (2) scraping and painting of bilges,
- (3) preventing oil leaks into the bilges,
- (4) following all the procedures stated in items (1), (2) and (3).

4.

40 03 02 01 05

WHEN USING AN INFLATABLE LIFERAFT IN COLD TEMPERATURES,
YOU WOULD:

- (1) deflate the roof and leave floor deflated for better retention of body heat,
- (2) leave roof inflated and inflate floor for better insulation,
- (3) deflate the roof and inflate floor for better insulation,
- (4) light the portable heater.

5.

40 03 03 01 81

THE MOST IMPORTANT FACTOR IN TREATING A SEVERE ANKLE
SPRAIN IS:

- (1) rest of the affected part,
- (2) exercise of the joint,
- (3) hot epsom salt application,
- (4) immediate immersion in ice water.

6.

40 03 03 02 05

ACCORDING TO THE SAFE WORKING PRACTICES REGULATIONS,
A SCAFFOLD MEANS:

- (1) a structure supported from above,
- (2) a working platform supported from below,
- (3) a working platform supported from above,
- (4) any of the above.

7. 40 03 04 01 05

UNDER THE OIL POLLUTION PREVENTION REGULATIONS, PERSISTENT OIL MEANS:

- (1) crude oil, fuel oil, heavy diesel oil and lubricating oil,
- (2) a mixture with any oil content,
- (3) gasoline or any petroleum product,
- (4) the substances described in items (2) and (3).

8. 40 09 02 01 09

AN INTERCOOLER AND AFTERCOOLER ARE USED IN CONJUNCTION WITH AN AIR COMPRESSOR:

- (1) to condense the oil and water vapour in the air,
- (2) to increase the pressure of the air delivered,
- (3) to reduce the temperature of the air between stages and after completion of the compression process,
- (4) for the reasons stated in items (1) and (3).

9. 40 11 03 00 34

COCKS RATHER THAN VALVES ARE USUALLY FITTED FOR BOILER WATER GAUGE GLASS MOUNTINGS BECAUSE:

- (1) they can be shut off more quickly should the gauge glass break,
- (2) they are easier to make and hence cheaper,
- (3) they are easier to maintain and repair,
- (4) the Ministry of Transport insist they be fitted.

10.

40 04 02 04 42

THE TYPE OF VALVE ILLUSTRATED IS CALLED A:

- (1) bolted bonnet globe valve,
- (2) union bonnet globe valve,
- (3) screwed bonnet globe valve,
- (4) straightway valve.

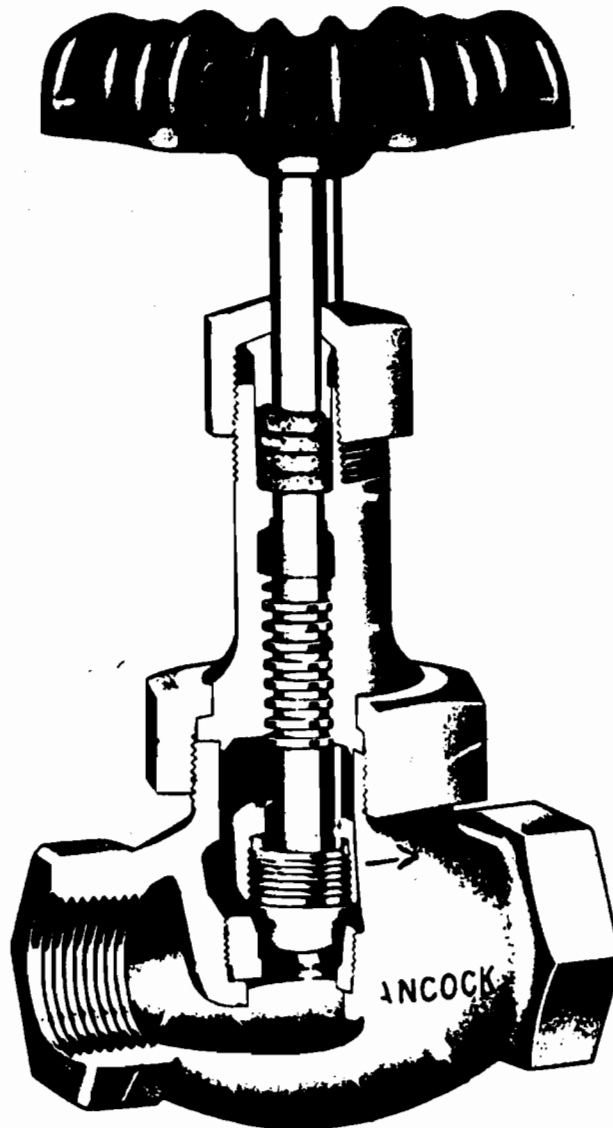

11.

40 11 01 00 08

THE TYPE OF BOILER ILLUSTRATED IS CALLED A _____
BOILER.

- (1) Benson,
- (2) water tube,
- (3) fire tube,
- (4) forced circulation.

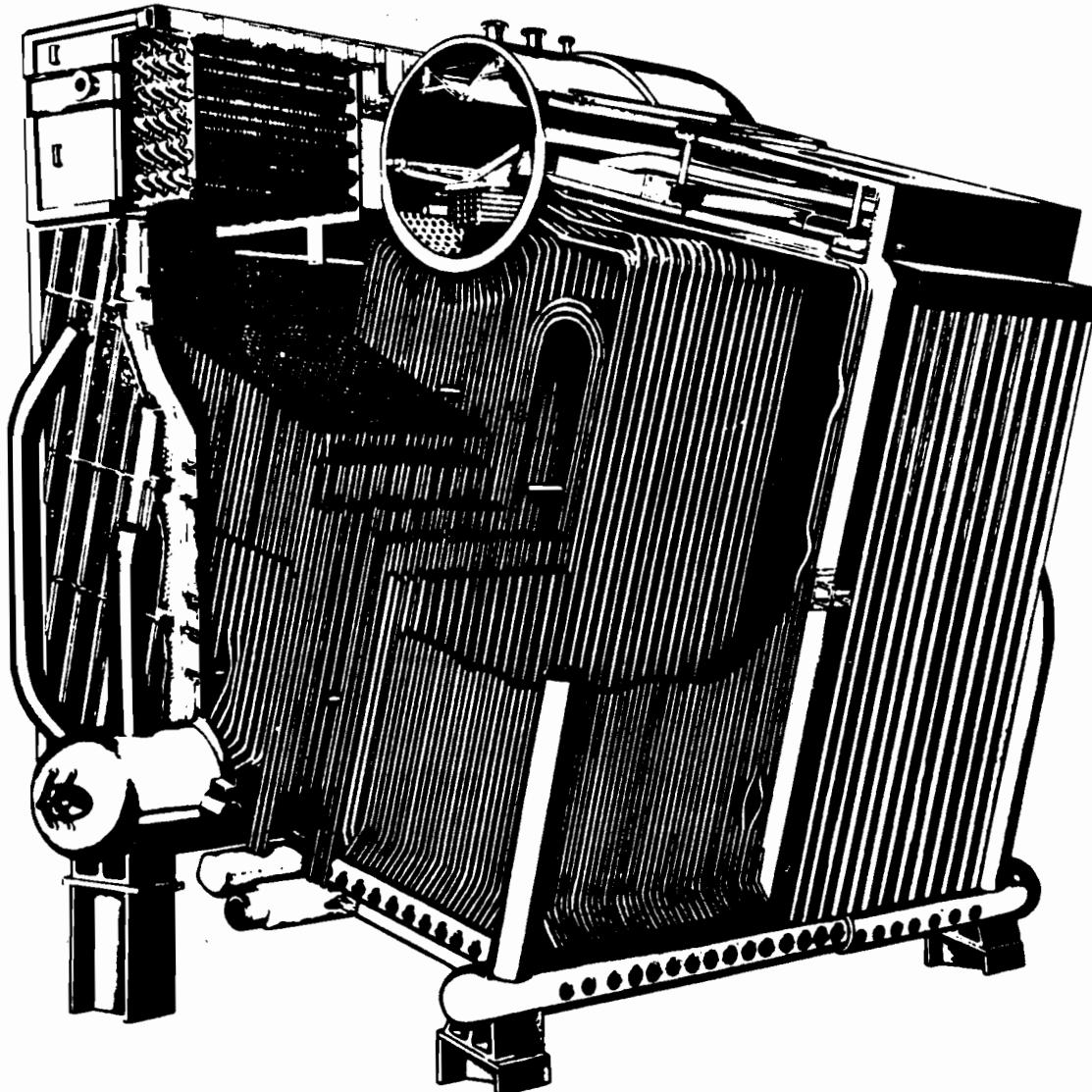

12.

40 12 01 00 14

THE TYPE OF ENGINE ILLUSTRATED HAS A POWER STROKE EVERY:

- (1) one revolution,
- (2) two revolutions,
- (3) three revolutions,
- (4) four revolutions.

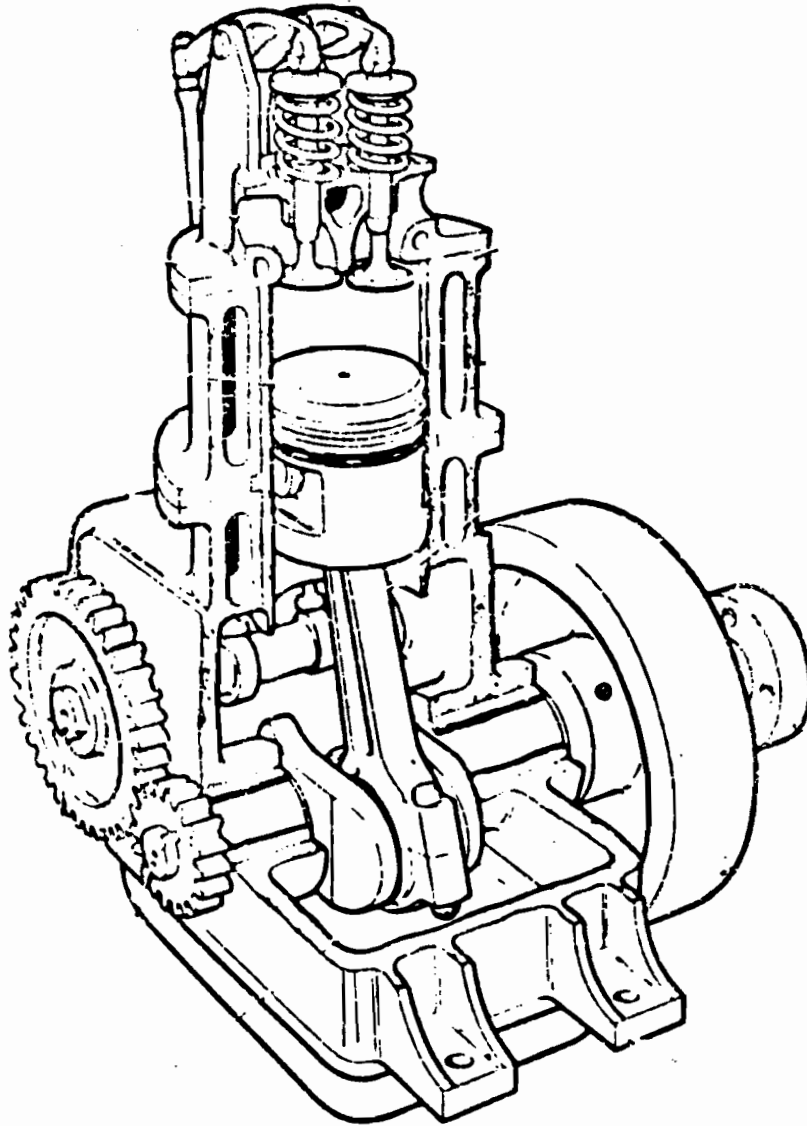

13.

40 12 05 00 08

A DIESEL ENGINE MULTI-CYLINDER FUEL PUMP IS CALIBRATED
TO ENSURE THAT THE AMOUNT OF FUEL DELIVERED TO:

- (1) the intake manifold is adequate,
- (2) the fuel filter is sufficient,
- (3) each cylinder of the engine is the same, to obtain accurate power balance,
- (4) all cylinders of the engine is the same, to obtain accurate fuel consumption.

