

Opposed piston pioneer powered ships for 70 years

The last British low speed two stroke engine - the distinctive Doxford opposed-piston design was withdrawn from production in 1980 after continual development from 1913, whose highlights are reviewed here

With experience gained in building marine reciprocating steam engines and turbines from the late 1870s, William Doxford and Sons - destined to evolve as a prolific and innovative

prolonged testing, however, and attention was transferred to the opposed-piston principle.

Refined over almost 70 years, the Doxford single-acting two-stroke

pistons exerted equal and opposite loads on the shafting, and thus the major stresses were not carried by the framing.

Construction of a single-cylinder opposed piston engine was started by Doxford in 1913, the design having a bore of 500mm and equal upper and lower strokes of 750mm, and a normal rating of 330kW at 130 rpm.

Testing from July 1914 was concluded by a 35-day full power endurance run in November/December that year, supervised by Lloyd's Register. The results more than fulfilled Doxford's expectations and justified the decision to proceed with a full-scale engine, although development was delayed by the First World War.

By 1919, however, the company was able to design its first full-scale oil engine: a four cylinder 580mm-bore/2 x 1,160mm upper and lower stroke model with a rating of 1,985kW at 77 rpm and operating with airless fuel injection.

(A single-cylinder experimental engine had been converted from air to airless injection in 1911, a departure from Dr Diesel's cycle. This step ahead of other designers had the effect of increasing the mechanical efficiency from 75 per cent to 82 per cent, with an accompanying reduction in fuel consumption as well as other benefits.)

Production and testing of the full-scale prototype was carried out in 1920/21 and the engine installed in Gothenburg-based Transatlantic Steamship's *Yngaren*, the first motor ship built by the Doxford yard, which was sea-trialled in mid-1921. A sisters hip, *Eknaren*, was similarly powered, both vessels remaining in service until sunk in 1943.

Furness Withy's *Pacific Commerce*, the first British ship to be equipped with this engine type (in February 1922), continued in service (latterly as *Norbryn*) until 1958.

In the 10 years from 1921 some 58 Doxford engines entered service with varying bore sizes and cylinder numbers.

A notable reference, *Bermuda*, was delivered to Furness Withy in 1926 with an 8,235kW propulsion plant comprising four 4-cylinder engines (600mm bore x 1,800mm combined stroke).

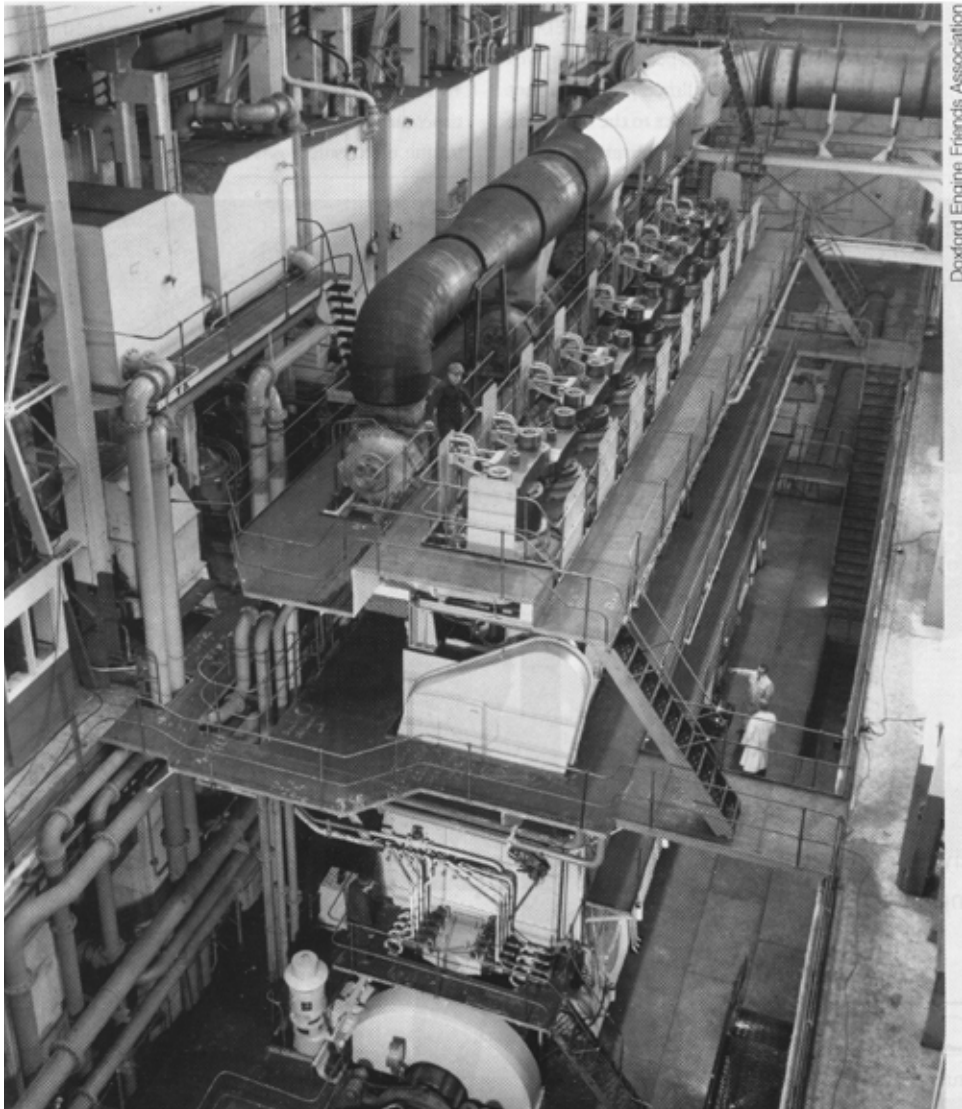

Doxford Engine Friends Association

The prototype nine-cylinder Doxford J-type engine on the Pallion testbed in 1964

shipbuilder at Sunderland on the river Wear in north east England - initiated R&D on diesel engines in 1906.

While generally associated with the opposed piston engine, Doxford's first design was a single piston crosshead machine, a single-cylinder version built in 1911 representing one unit of an envisaged four-cylinder marine engine with an output of around 735kW. A number of design weaknesses were revealed during

opposed-piston design was characterised by two pistons in each cylinder, moving in opposite directions from a central combustion chamber.

Air was compressed in the cylinder as the pistons moved towards each other and, shortly before reaching the point of minimum volume between the pistons (inner dead centre), fuel was injected through nozzles into the combustion space. In transmitting power to the crankshaft the upper and lower

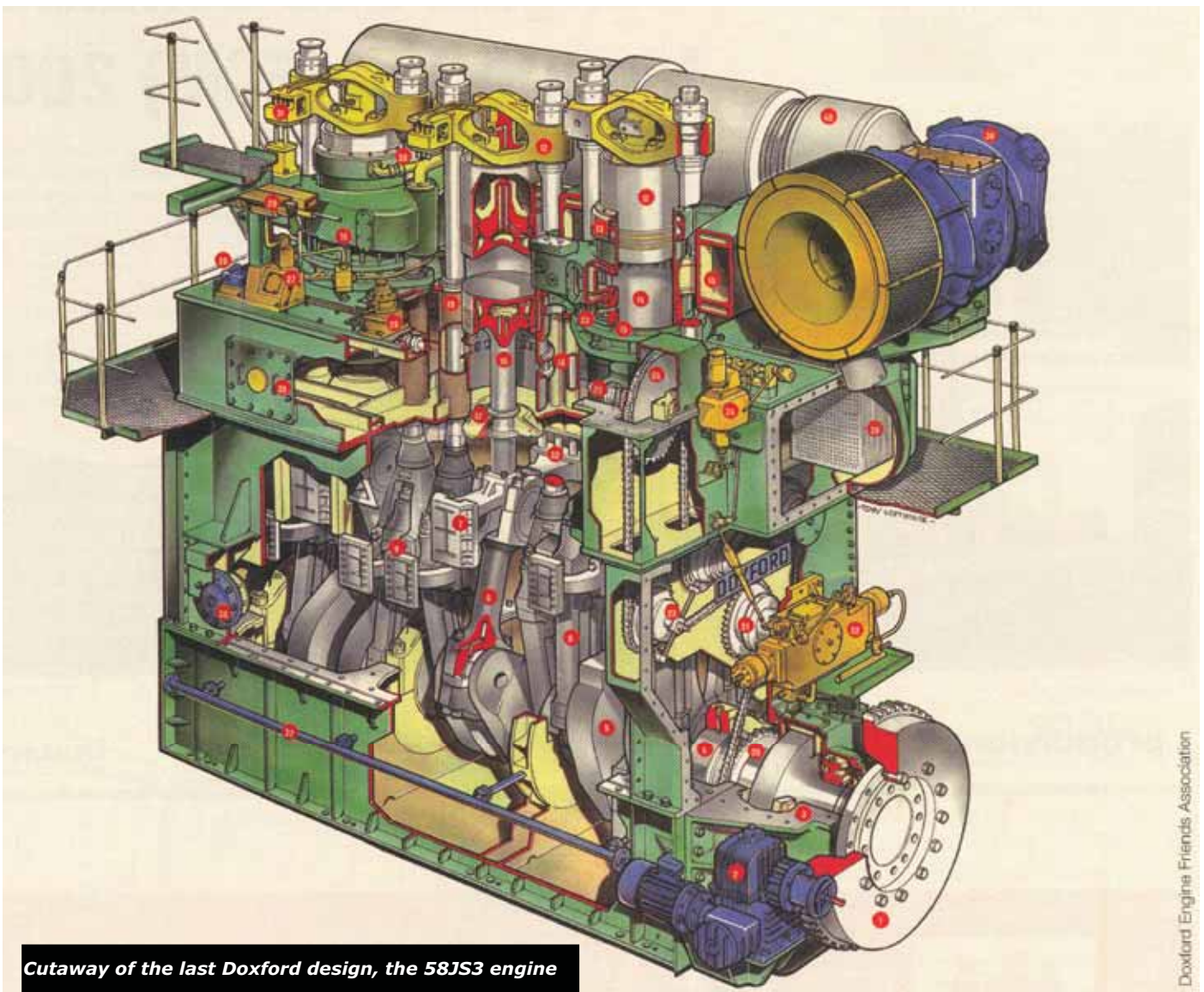

Doxford Engine Friends Association

Cutaway of the last Doxford design, the 58JS3 engine

It was around this time that the 'balanced' engine was introduced, exploiting the differential stroke arrangement used by Doxford on a design in 1915. A redesign of reciprocating parts to achieve weight adjustments was also carried out, along with modifications to the engine structure and alteration of the firing sequence. These refinements proved successful and secured an engine free from vibration.

In 1928 Doxford ventured again into the smaller and lower-powered engine arena (visited first in 1915/16), producing two engines of 400mm bore and 1,300mm combined stroke with a normal rating of 590kW at 145 rpm. The first was fitted to the small tanker *Freshmoor* and led a long and useful life operating at 480kW.

A much advanced and completely new engine appeared in 1933, featuring all-welded fabricated steel columns and entablature. The first examples retained the cast iron bedplate but this also soon gave way to a welded fabricated structure.

The UK's Reardon Smith took delivery in 1933 of the first two of these engines, each having four cylinders with a 600mm bore and 2,320mm combined stroke: the

forerunners of a large number of such designs built by Doxford and its licensees. The debut vessel *Devon City*- sea trialed in December 1933 - continued in operation until July 1967 (not bad for a prototype engine).

In 1931 Karl Otto Keller (a Swiss designer who had joined Doxford in 1905) conceived the idea of using the side crankwebs, in circular form, as main journals (61-inch - 1,549mm - in diameter). The aim was to shorten the engine, gaining benefits in reduced weight and cost. Despite extensive experimental work, the project was not pursued (it was considered that an engine with large bearings at that time would not be successful) but the concept was adopted years later for the J-engine in 1964/65.

A long line of economy ships emerged from the Doxford yard in 1934/35, each propelled by a three-cylinder 520mm-bore/2,080mm-combined stroke engine developing 1,325kW

With the trend to higher ship speeds, this engine was progressively replaced by a three cylinder 560mm-bore/2,160mm-combined stroke design producing 1,620kW; and then by three- and four-cylinder engines of 600mm-bore/2,320mm combined

stroke, respectively developing 1,840kW and 2,430kW. A 670mm-bore design subsequently appeared, the four cylinder version yielding 3,235kW.

In 1938/39 a five-cylinder 725mm-bore/ 2,250mm-combined stroke engine evolved, four examples with a total rating of 19.1MW being installed in the Shaw Savill & Albion liner *Dominion Monarch* (reportedly then the highest-powered motor ship in the British fleet).

During the Second world War Doxford built some 107 engines in five-and-a-half years and at one time was testing an engine almost every two weeks. The three-cylinder 1,840kW model was economical, with a daily fuel consumption of only six tons.

In the early post-War years the company and its 13 UK licensees and nine overseas licensees were well deployed in building engines to replace wartime losses.

US-based licensee Sun Shipbuilding & Dry Dock completed the first examples of Doxford-type geared 'medium speed' engines in the early 1940s. These two six-cylinder Sun-Doxford designs - with a 21-inch bore and 60 inch (523 x 1,524mm) combined stroke- had a normal

rating of 3,310kW at 180 rpm but were capable of 25 per cent overload to deliver an output of 4,140kW at 195 rpm. The pair was geared to a single propeller shaft to drive the *Fairsea*.

Other interesting features included the use of separate scavenge air blowers driven by high speed electric motors.

Engines of higher powers were progressively introduced, culminating in the early 1950s with a six-cylinder 750mm-bore/2,500mm-combined stroke design developing

6,810kW at 110 rpm.

It was now that Doxford ran into its first real disaster with an engine suffering broken crankshafts. Modifications to the crankshaft achieved a final design which, with a circular centre coupling, effectively overcame the problem. Ships powered by this size of engine continued to operate successfully for many years.

There were also a number of crankshaft failures on the 600mm-bore 'close centre' engine but these again were resolved. It should be

stressed, however, that not all such failures with this engine size arose from design. Many were the result of mal-operation and inadequate maintenance; and, as far as possible, Doxford introduced modifications to overcome the human failings.

(In fairness, it should be noted that in some European repair yards there were as many broken crankshafts from other engine makes as there were from Doxford engines. The latter nevertheless came in for severe criticism and many Doxford licensees turned their interest to rival designs.)

Before these troubles, in 1950, Doxford had started to investigate turbocharging its opposed-piston engine. After some preliminary tests it decided to proceed with designing and constructing a three-cylinder 600mm-bore /2,000mm-combined stroke engine to run at 125 rpm, with turbocharging boosting output to 30 or 50 per cent above that of a normally aspirated engine.

Following prolonged shop testing, the resulting engine was installed in *British Escort*, replacing the original four-cylinder 600mm-bore/2,320mm-combined stroke unit. A slightly increased ship speed and reduced fuel consumption were reported, leading to the production of a series of turbocharged engines from Doxford and its licensees.

Much other development work meanwhile had been carried out. The old Doxford fuel injection system was replaced by a new design featuring a more compact main fuel pump; a new air starting system with a rotary distributor was also produced.

Furthermore, in the early 1950s - in order to eliminate the often serious effects of corrosion of the crankshaft and other working parts in the crankcase - experiments were carried out on a single-cylinder test engine which had a diaphragm plate and gland completely isolating each cylinder from the crankcase, while maintaining easy access to the piston rod gland.

Exhaustive tests yielded what became known as the Doxford Diaphragm engine (hence the nomenclature LBD). Oil-cooled lower pistons were also introduced during this period, eliminating the risk of contaminating the lube oil with cooling water.

Continued investigation, along with operational feedback from the turbocharged LBD engine, resulted in a BDS range incorporating many improvements and dispensing with the lever-driven scavenge air pumps fitted to the LBD series. The new programme took the power band up to a maximum 8,100kW from six cylinders.

Although the Diaphragm design was primarily introduced to secure protection for the crankcase, the Doxford engine had always

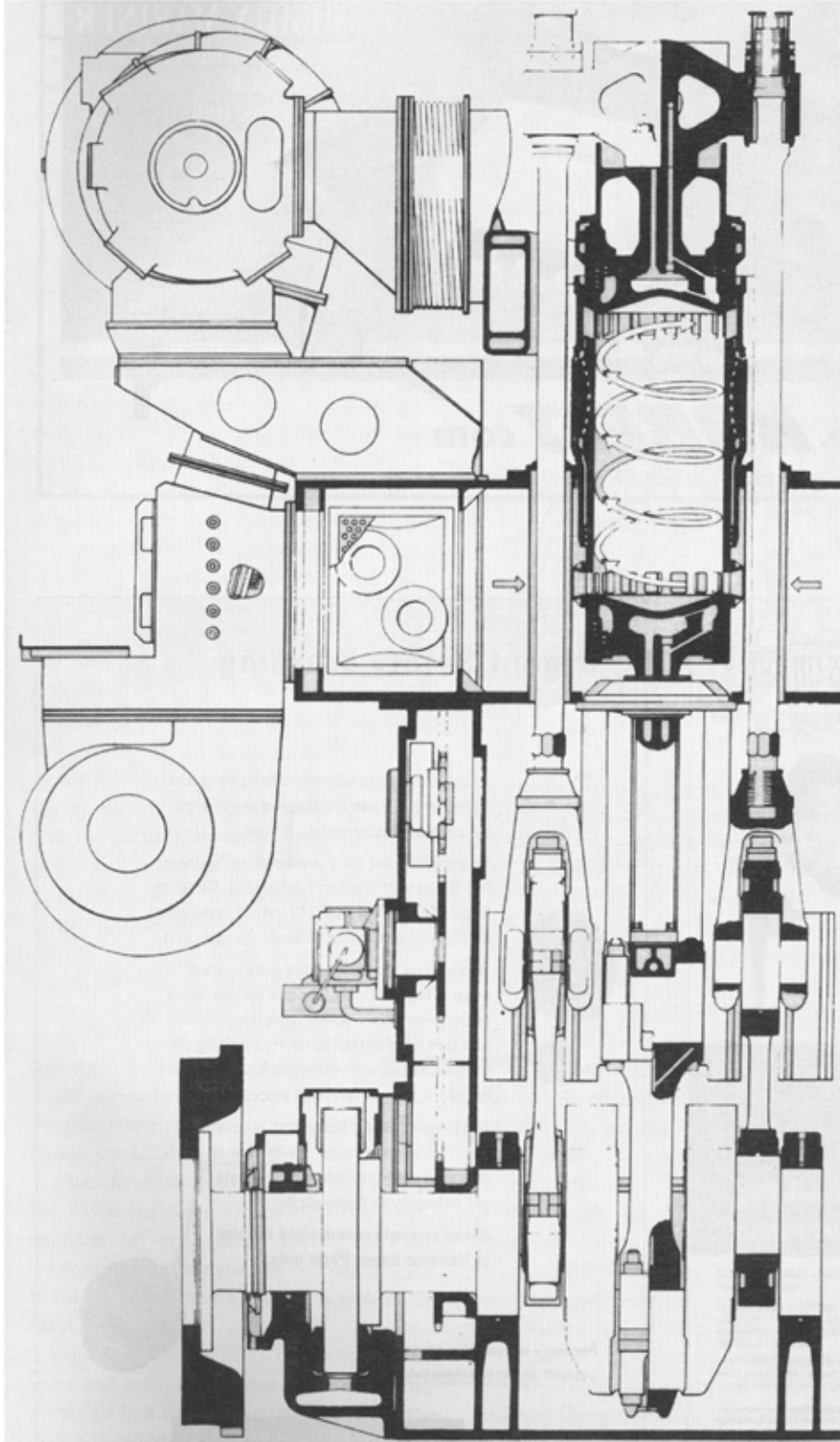

Section through the end cylinder of a Doxford 58JS engine

been suitable for heavy fuel oils, as early as 1913 proving its capability to burn all grades.

In 1928, in association with the British Tanker Co, a system of dual centrifuging of heavy oils was introduced on *British Justice* and later ships. Further substantial investigation and experimental work was performed, including determining the effects of combustion residues on lubricating oil and the consequent actions necessary to ensure continual and effective purification.

Most Doxford engines subsequently operated almost exclusively on heavy fuels of varying qualities, only using marine diesel oil for starting and manoeuvring.

In the late 1950s Doxford designers were armed with more advanced designs which, while retaining the basic well-tried principles of the opposed-piston engine, introduced a number of radical changes. The most important of these were a more compact and stiffer crankshaft and three-piece cylinders.

A short and stiff crankshaft made it possible to dispense with the spherical bearings previously used, the result being a shorter and lighter engine of higher power rating than its predecessors while retaining the traditional simplicity and perfect balance.

By the time this P-engine entered production - the first was sea-trialled in the *Montana* in February 1961 - it had completed some 12 months intensive testing. The six-cylinder 670mm-bore/2,100mm-combined stroke design nominally developed 7,350kW at 120 rpm but had been run on the testbed for an hour at 8,090kW/127 rpm.

Some 48 P-engines were built and reportedly gave satisfactory service after certain problems were effectively resolved. Apart from Doxford's Pallion works, the engines were built under licence by the UK's Hawthorn Leslie and Chantiers de Provence at Marseilles.

In 1962, however, it was decided that a new design was desirable because the weight of the crankshaft of a larger bore P-type engine would become prohibitive and, due to other factors, it was not possible to build the P-engine with more than six cylinders. This was considered the maximum number for operation on the opposed-piston principle due to torsional vibration problems imposed by the comparatively flexible crankshaft.

That flexibility was mainly overcome in the P-type engine by a more rigid crankshaft, applying a very large overlap of the crankpin and bearing journals, and reducing the throw of the side cranks by using large diameter main bearing journals.

Altering the crankshaft - combining the side webs and main journal into one large bearing - resulted in a much stiffer shaft; and, with the saving in length, it became possible to produce engines with up to nine cylinders.

An output of 14.7MW was targeted

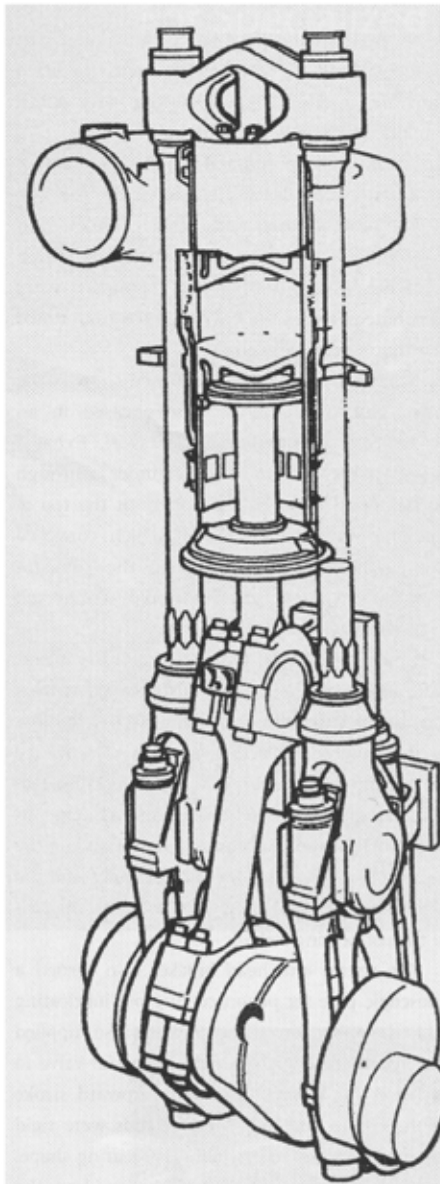

Main running components of the 58JS engine. The many similarities with Doxford J-type engines included the combined side rod crankweb and main bearing journals to minimise cylinder centre distances

from the new J-engine (twice the limit of the P-type), which was considered quite sufficient to meet the demands of the largest ships then being built. A nine-cylinder engine with a bore of 760mm and a combined stroke of 2,180mm, designed to operate at 115 rpm on a mean indicated pressure of 135 lb/in², was running on the testbed in December 1963.

Shop trials continued for over a year before this prototype engine was installed in the 69,000 dwt tanker *North Sands*, which was built and owned by Doxford and used as a floating testbed after entering service in late November 1965. Testing and operating experience influenced further development and necessary changes which resulted in a compact engine with clean lines.

The range of 760mm-bore J-engines extended from a four-cylinder model developing 7,350kW to a nine-cylinder model delivering 16.55MW. A smaller version also became available with a

DOXFORD 58JS

Bore	580mm
Stroke, upper/lower	340mm/880mm
Speed	220 rpm
Power/cylinder, mcr	1,349kW
Cylinders	3, 4, 5, 6
Output range	4,047-8,094kW
Mean effective pressure	11.42 bar
Compression pressure	50 bar
Maximum pressure	85 bar
Piston speeds, upper/lower	2.5/6.45m/s
Power/weight ratio	41 kW/tonnes
Scavenge pressure (abs)	2.3 bar
Exhaust temp, after turbine	320° C
Injection pressure, full load	600 bar
Fuel consumption, full load	201 g/kWh
Engine weights:	
- 58JS3	110 tonnes
- 58JS4	142 tonnes
- 58JS5	176 tonnes
- 58JS6	205 tonnes
Component weights:	
- upper piston with beam	1.368 tonnes
- lower piston with rod and gland	0.733 tonnes
- cylinder liner, complete	3.132 tonnes
- side connecting rods, each	1.120 tonnes

670mm-bore and 2,140mm-combined stroke, the four- and six-cylinder models respectively rated at 5,880kW and 8,825kW. A 580mm-bore variant completed the programme.

Fuel injection operated on the common rail principle, in which timing valves, activated by cams on the camshaft, controlled injection from a high pressure manifold through spring-loaded injectors to the cylinders. Fuel was delivered to the manifold by a multi-plunger pump mounted at the aft end of the engine; and the pressure was maintained at the desired level by a pneumatically-operated spill valve.

The last J-type engines were turbocharged on the constant pressure principle after a changeover from the original impulse charging system. Three and four-cylinder models were specified with one turbocharger mounted at the forward or aft end, while two or three turbochargers were fitted to seven, eight and nine-cylinder models. Between each turbocharger and the entablature was a finned-tube seawater-cooled after cooler. An electric auxiliary blower was provided for slow running or emergency duties.

Responding to competition from four-stroke trunk piston diesel engines, Doxford pursued development of the Seahorse medium speed design between 1970 and 1975, exploiting the fundamental principles of the J-type engine. The joint venture with Doxford licensee Hawthorn Leslie on Tyneside sought to offer a heavy fuel burning crosshead engine with an output speed of 300 rpm for gearing down to the 80-100 rpm required by the large propellers of supertankers.

A 580mm-bore prototype Seahorse achieved an impressive output of 1,850kW per cylinder. No engines were built commercially but many of the design features were subsequently applied to the last member of the Doxford family, the 58JS (J-type short-stroke).

In its final years - design work started in autumn 1976 - Doxford developed the 58J S engine in response to escalating fuel prices, offering compact, direct-drive machinery for smaller ships and the ability to burn low grade bunkers. The piston stroke was shortened from that of the normal J-type engine to facilitate a faster running speed of 220 rpm, with reliability underwritten by Seahorse project technology.

An output of 1,350 kW/cylinder was a considerable advance on the conventional J-type engine of the same 580mm-bore size. It was intended to offer the 58JS design in three, four, five and six-cylinder versions, with larger bore (670mm and 760mm) models also envisaged later.

Only ten 3-cylinder models were produced, however, the first 58J S3 engine completing testbed trials in 1978 and yielding 4,050kW at 220 rpm. One of seven such engines delivered for feeder container ship propulsion projects, this unit was installed in the 300 TEU *City of Plymouth*, built by the UK's Appledore Shipbuilders for Ellerman City Liners.

British Shipbuilders - the state corporation by then had incorporated the company in its portfolio - decided to stop production of Doxford engines as the last of these 58J S3 engines left the works. The final completion, in 1980, was a 76JC4R engine delivered to a yard in Canada for powering the bulk carrier *Canadian Pioneer*.

The three-cylinder opposed-piston 58JS3C engine was conceived as a direct-drive challenge to geared medium speed four-stroke engines in propelling smaller ships, offering the added benefit of residual fuel burning capability.

Although based on the larger Doxford J - type engine, the 58J S design featured some significant refinements, addressing the higher rotational speed and relatively short piston stroke.

The engine bedplate, columns and entablature were of all-welded fabricated construction to create a robust structure of optimised weight. A single-piece crankshaft had each cylinder section made up of three throws, with the two side rods connected to the upper piston and the centre crank to the lower piston.

The side crank webs were circular and doubled as main shaft journals of large diameter. Each centre crank was an integral steel casting or forging and the centre crankwebs and shrunk on to the side pins.

The cylinder liners were one-piece special iron castings with the water

cooling surface around the combustion area formed by bore holes drilled at an angle to the liner bore. The central part of the liner in the combustion area was fitted with fuel injectors, an air starting valve and a combined relief and indicator valve.

Liners were positioned in the entablature by a water-cooled jacket bolted to the top face of the entablature, and each cylinder unit assembly was cooled by distilled water. Equally-spaced lubricating points were distributed around the liners and fed from timed distributor-type lubricators.

Scavenge ports machined in the lower part of the liner were encased in an air deflector to produce an air swirl. Exhaust gases passed from the cylinder through ports around the whole periphery at the top of the liner into exhaust belts, which conveyed the gas from the cylinders to the constant pressure exhaust gas manifold connected to the turbocharger.

Upper and lower forged steel piston heads were interchangeable, their dish-shaped crowns forming a near-spherical combustion chamber at the inner dead centre position. The centre connecting rod had its lower end machined to take the upper half steel-backed and whitemetal lined shell of the bottom-end bearing, while the top end was machined for shell bearings and the lower half shell and keep were bolted to the foot of the connecting rod.

The centre crosshead bracket also carried a telescopic pipe for piston cooling oil; lubricating oil to the centre top end bearing was also supplied through a telescopic pipe with a special valve to increase the oil pressure on the upward stroke of the connecting rod. The side rods were rigid castings designed to maintain the bearing shape, and long pre-stressed bolts took the load from the top end bearings to the side crank pin keeps.

Constant-pressure turbocharging was exploited, with one turbocharger deployed for normal running conditions; an electrically-driven auxiliary blower was engaged during slow running and manoeuvring.

As with the larger Doxford J-type engines, the fuel system operated on the common rail principle, with fuel delivered to a high pressure main by a multi-plunger pump. The fuel injectors serving each cylinder opened when timing valves were operated by cams on the chain-driven camshaft, the opening and timing controlled by the governor.

An unusual feature of the three-cylinder 58JS engine was a starting air positioner fitted to the crankshaft, acting automatically to turn the shaft away from any dead spots so that starting could take place in the normal manner. Ships equipped with this pneumatically-actuated device, however, rarely used it.

Acknowledgements: Doxford Engine Friends Association; Tyne & Wear Museums, Newcastle upon Tyne, England

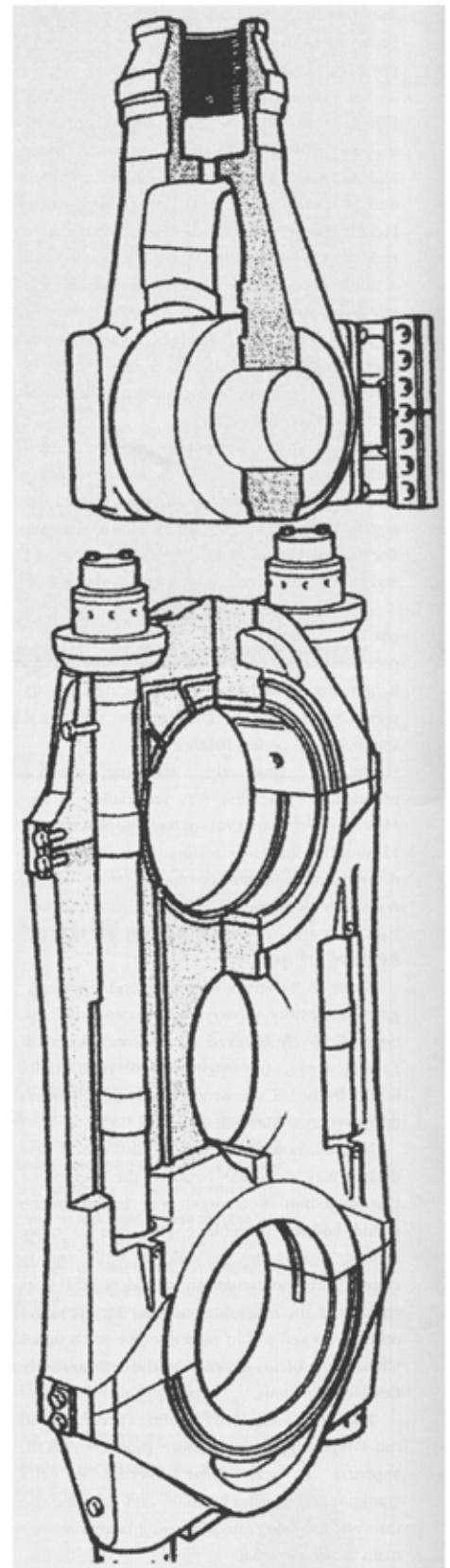

Side crosshead and connecting rod for the 58JS3. Long tiebolts took the main tensile loads, with a cast centre section carrying the smaller compressive stresses

Marine Propulsion - April/May - 2007
www.mpropulsion.com